



Manufactured by means of a sandblasting process plate by plate, this substrate is delivered with a quality control ensuring the reproducibility of roughness [1]. These plates are certified with topography parameters in compliance with ISO 24443:2021, ISO/CD 23675, FDA monograph 2011 and Boots Star Rating system rev. 2011.

PROCESS DESCRIPTION

Overall size (WxLxH): 50 mm x 50 mm x 1.5 mm
 Weight: 4.5 g
 Manufacturing process: Plate by plate
 Package contenance: 50 plates

Spreading area: 47 mm x 47 mm
 Temperature: Optimal temperature range 20-40°C
 Material: PMMA (polymethylmethacrylate)
 Use: To use only one time (cannot be cleaned)

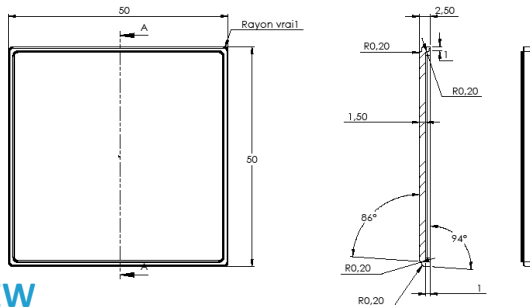

VIEW

2D

3D

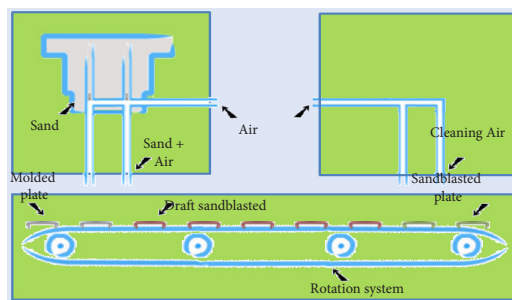

One plate

One package

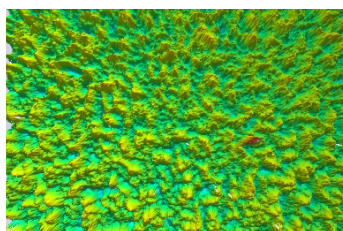

TOPOGRAPHIC PARAMETERS

Surface profile characteristics of the substrate is measured covering at least a surface area of 10 mm x 5 mm in 15- μ m intervals. Non-contact surface topographic analysis is conducted using a lab work station consisting of an optical sensor, a motion controller, an x-y translation stage, and microtopography software. A sensor based on a white light chromatic aberration principle is used which allows for a high resolution: 10 nm vertically and 1 μ m horizontally.

Parameter	Ra	Rv	Rdq	A1	Ssc	Vvv
Target value	4,188 $\pm 0,514$	11,402 $\pm 2,499$	11,004 $\pm 1,938$	238,252 $\pm 72,663$	0,032 $\pm 0,015$	8,701 . 10 ⁻⁴ $\pm 2,325 . 10^{-4}$

Ra (μ m): The mean arithmetic deviation of the roughness profile.
 Rv (μ m): The maximum depth of profile valleys within a sampling length.
 Rdq ($^{\circ}$): The root-mean-square slope of the profile within a sampling length.
 A1 (μ m².mm⁻¹): The upper area, i.e. the area of the rest overs of the peaks extending above an average profile \pm kernel.
 Ssc (L. μ m⁻¹): The arithmetic mean summit curvature of the surface, which indicates the meanform of peaks and valleys.
 Vvv (mm³.m⁻²): The volume of void in the valleys, i.e., the volume of rest overs of valleys extending below an average profile \pm kernel.

PLATE OPTICAL CHARACTERISTICS

Limits for the treated plate transmission values are: 290 nm >60 %T - 300 nm >69 %T - 320 nm >81 %T

INFORMATION AND GENERAL TIMETABLE



[1] S. Miksa, D. Lutz and C. Guy. Sandblasting to Improve the Reproducibility of In vitro Sunscreen Evaluation, Cosmetics & Toiletries, April 2014

